

REVISION HISTORY				
ZONE	REV	DESCRIPTI	DATE	APPROVED
	1	prop verplaatst	17-01-08	tekenaar

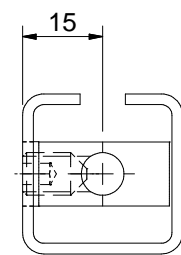
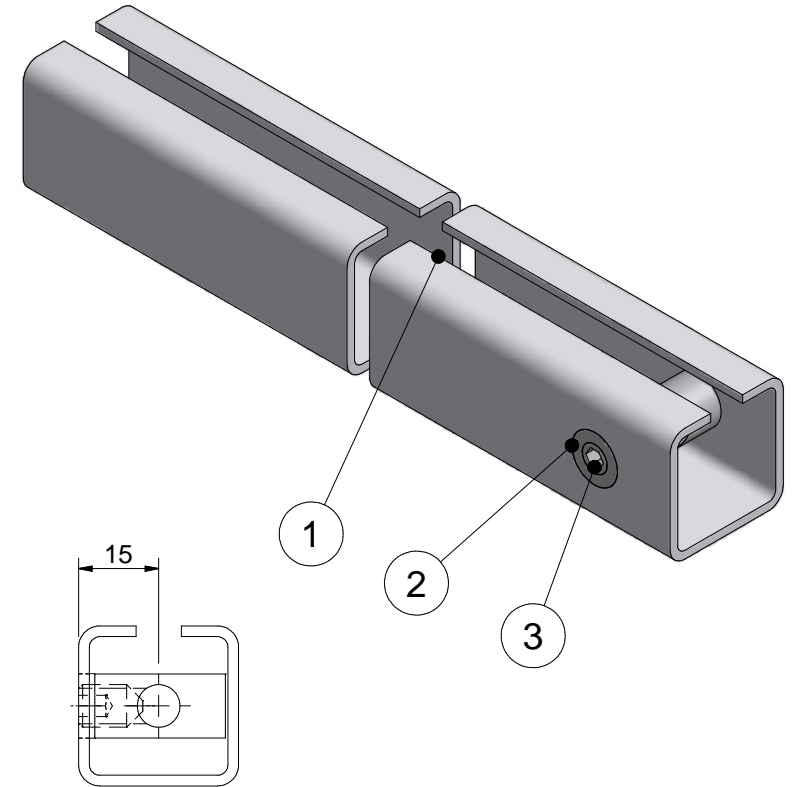
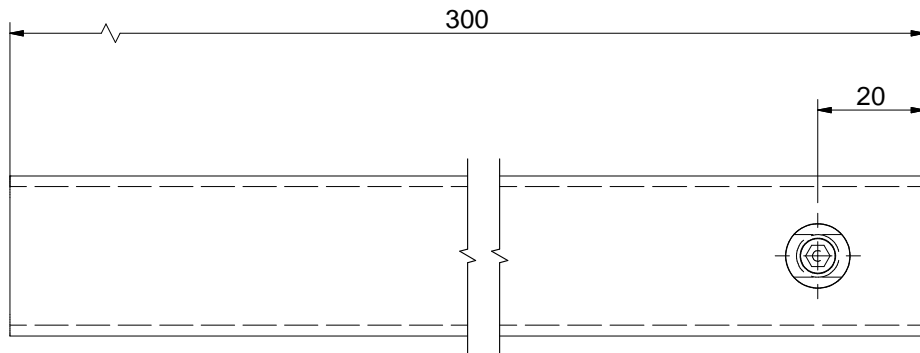

3	1	Stelschroef met binnenzeskant M8x12 en kegelpunt SMIT	07800.080.012	Steel, Mild	
2	1	Prop RVS	605194	RVS 303 NR 1.4305	00
1	1	Strebenprofiel 30x30 1N	605156_001	Alu AW-6060	00
ITM	QT	DESCRIPTION	PART NR	MATERIAL	REV NR
Threatment		Units	MM	Roughness	Unspecified tolerances
Aftertreatment		Not on scale bases	25	√ 3.2	According NEN-ISO 1101
Layer thickness		Reference	(25)		Dim ± 0,5 Angle ± 0,5°
Description: Verl. strebenprofiel 30x30 1N L=300			Scale	1:1	Engineer: TM
Project: Sjabloon koker			Revision	00	Checked by:
 POSTBUS 151 3400 AD IJSSELSTEIN, HOLLAND TELEPHONE : 0031 - (0)30 - 6877940 FAX : 0031 - (0)30 - 6875688 E-MAIL : HMB@HMBPROFITTOOLS.NL			Projection		Date: 6-11-2007
			Sheetsize	A3	Date:
					Drawing number
					605156

THIS DRAWING REMAINS PROPERTY OF HMB PROFIT TOOLS AND MAY NOT BE COPIED WITHOUT OUR WRITTEN CONSENT.